

INTRODUCTION

CONTENTS

	page		page
GENERAL INFORMATION		METRIC SYSTEM	7
BODY CODE PLATE	2	THREADED HOLE REPAIR	7
FASTENER IDENTIFICATION	4	TORQUE REFERENCES	7
FASTENER USAGE	7	VEHICLE IDENTIFICATION NUMBER	1
INTERNATIONAL VEHICLE CONTROL AND		VEHICLE SAFETY CERTIFICATION LABEL	1
DISPLAY SYMBOLS	4	VIN CHECK DIGIT	2

GENERAL INFORMATION

VEHICLE SAFETY CERTIFICATION LABEL

A vehicle safety certification label is attached to the left side B-pillar (Fig. 1). This label indicates date of manufacture (month and year), Gross Vehicle Weight Rating (GVWR), Gross Axle Weight Rating (GAWR) front, Gross Axle Weight Rating (GAWR) rear and the Vehicle Identification Number (VIN). The Month, Day and Hour of manufacture is also included.

All communications or inquiries regarding the vehicle should include the Month-Day-Hour and Vehicle Identification Number.

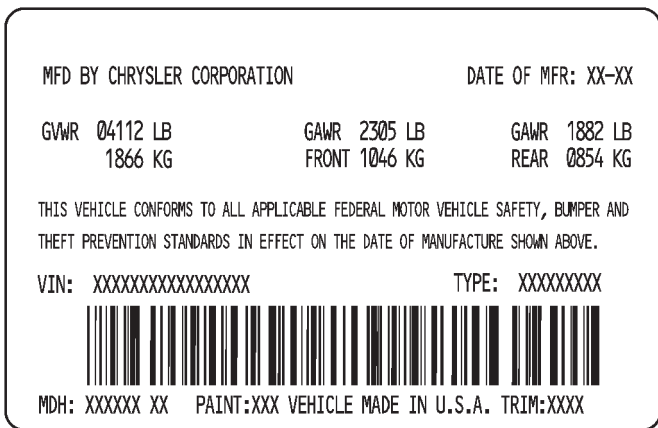

800dfad9

Fig. 1 Vehicle Safety Certification Label

VEHICLE IDENTIFICATION NUMBER

The Vehicle Identification Number (VIN) is located on the upper left corner of the instrument panel, near the left windshield pillar (Fig. 2). The VIN consists of 17 characters in a combination of letters and numbers that provide specific information about the vehicle. Refer to VIN Code Breakdown table for decoding information.

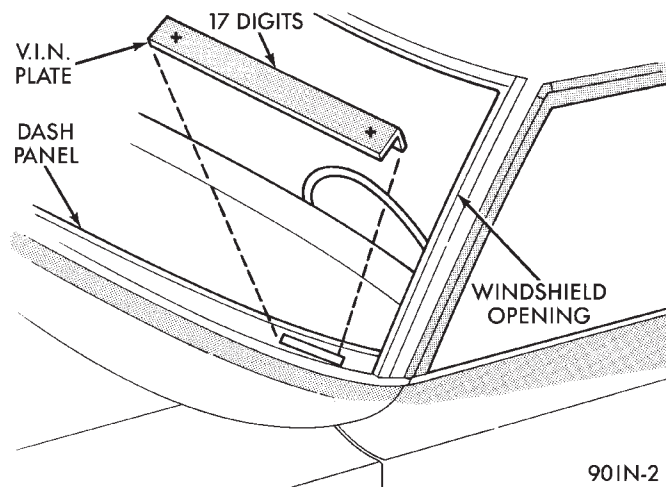

Fig. 2 Vehicle Identification Number (VIN Plate)

GENERAL INFORMATION (Continued)

VIN CODE BREAKDOWN

POSITION	INTERPRETATION	CODE = DESCRIPTION
1	Country of Origin	1 = United States
2	Make	B = Dodge C = Chrysler P = Plymouth
3	Vehicle Type	3 = Passenger Car
4	Passenger Safety	E = Active Driver and Passenger Air Bags
5	Car Line	J = Chrysler, Cirrus J = Dodge, Stratus J = Plymouth, Breeze 2 = Chrysler, Breeze (sold in Mexico) 2 = Chrysler, Cirrus (sold in Mexico) 2 = Chrysler, Stratus (sold in Mexico)
6	Series	4 = High Line 5 = Premium 6 = Sport
7	Body Style	6 = 4 Door Sedan
8	Engine	C = 2.0L 4 Cyl 16V Gasoline SOHC H = 2 .5L 6 Cyl Gasoline SOHC S = 2.4L 4 Cyl 16 V DOHC Turbo (sold in Mexico) X = 2.4L 4 Cyl 16V Gasoline DOHC
9	Check Digit	0 through 9 or X
10	Model Year	X = 1999
11	Assembly Plant	N = Sterling Heights Assembly
12 through 17	Sequence Number	6 digit number assigned by assembly plant.

VIN CHECK DIGIT

To protect the consumer from theft and possible fraud the manufacturer is required to include a Check Digit at the ninth position of the Vehicle Identification Number. The check digit is used by the manufacturer and government agencies to verify the authenticity of the vehicle and official documentation. The formula to use the check digit is not released to the general public.

BODY CODE PLATE

LOCATION AND DECODING

The Body Code Plate (Fig. 3) is located in the engine compartment on the driver side strut tower. There are seven lines of information on the body code plate. Lines 4, 5, 6, and 7 are not used to define service information. Information reads from left to right,

starting with line 3 in the center of the plate to line 1 at the bottom of the plate.

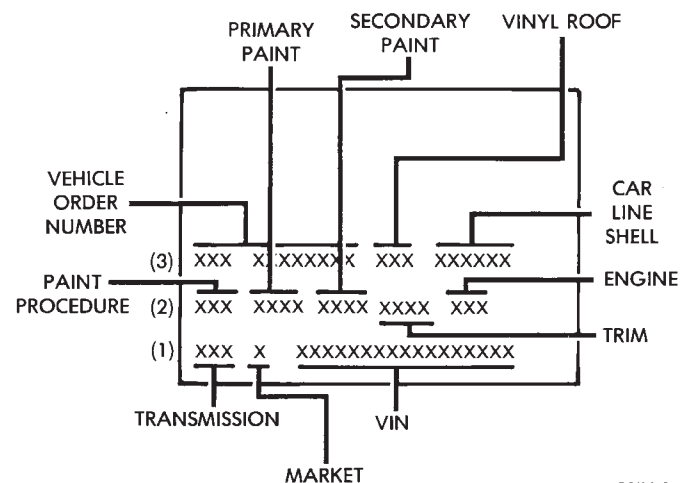

Fig. 3 Body Code Plate

GENERAL INFORMATION (Continued)

BODY CODE PLATE – LINE 3**DIGITS 1 THROUGH 12**

Vehicle Order Number

DIGITS 13, THROUGH 15

Vinyl Roof Code

DIGITS 16 AND 17

Open space

DIGITS 18 AND 19

Vehicle Shell Line

- JA

DIGITS 20

Carline

- C = Chrysler
- D = Dodge
- H = Plymouth

DIGIT 21

Price Class

- E = Economy
- H = High Line
- L = Low Line
- M = Mid Line
- P = Premium
- S = Special/Sport
- X = Performance Image

DIGITS 22 AND 23

Body Type

- 41 = Four Door Sedan

BODY CODE PLATE LINE 2**DIGITS 1, 2, AND 3**

Paint procedure

DIGIT 4

Open Space

DIGITS 5 THROUGH 7

Primary paint

See Group 23, Body for color codes.

DIGIT 8 AND 9

Open Space

DIGITS 10 THROUGH 12

Secondary Paint

DIGIT 13 AND 14

Open Space

DIGITS 15 THROUGH 18

Interior Trim Code

DIGIT 19

Open Space

DIGITS 20, 21, AND 22

Engine Code

- ECB = 2.0L Four Cylinder SOHC Gasoline
- EEB = 2.5L Six Cylinder SOHC Gasoline
- EDZ = 2.4L Four Cylinder DOHC Gasoline

DIGIT 23

Open Space

BODY CODE PLATE LINE 1**DIGITS 1, 2, AND 3**

Transaxle Codes

- DGL = 41TE 4-speed Electronic Automatic Transaxle
- DD5 = NV T350 5-Speed Manual Transaxle

DIGIT 4

Open Space

DIGIT 5

Market Code

- C = Canada
- B = International
- M = Mexico
- U = United States

DIGIT 6

Open Space

DIGITS 7 THROUGH 23

Vehicle Identification Number

























- Refer to Vehicle Identification Number (VIN) paragraph for proper breakdown of VIN code.

IF TWO BODY CODE PLATES ARE REQUIRED

The last code shown on either plate will be followed by END. When two plates are required, the last code space on the first plate will indicate (CTD)

When a second plate is required, the first four spaces of each line will not be used due to overlap of the plates.

GENERAL INFORMATION (Continued)

 HIGH BEAM	 FOG LIGHTS	 HEADLIGHTS, PARKING LIGHTS, PANEL LIGHTS	 TURN SIGNAL	 HAZARD WARNING	 WINDSHIELD WASHER
 WINDSHIELD WIPER	 WINDSHIELD WIPER AND WASHER	 WINDSCREEN DEMISTING AND DEFROSTING	 VENTILATING FAN	 REAR WINDOW DEFOGGER	 REAR WINDOW WIPER
 REAR WINDOW WASHER	 FUEL	 ENGINE COOLANT TEMPERATURE	 BATTERY CHARGING CONDITION	 ENGINE OIL	 SEAT BELT
 BRAKE FAILURE	 PARKING BRAKE	 FRONT HOOD	 REAR HOOD (TRUNK)	 HORN	 LIGHTER

80a53b2d

Fig. 4 International Control and Display Symbols

INTERNATIONAL VEHICLE CONTROL AND DISPLAY SYMBOLS

The graphic symbols illustrated in the following International Control and Display Symbols chart (Fig. 4) are used to identify various instrument controls. The symbols correspond to the controls and displays that are located on the instrument panel.

FASTENER IDENTIFICATION

THREAD IDENTIFICATION

SAE and metric bolt/nut threads are not the same. The difference is described in the Thread Notation chart (Fig. 5).

GRADE/CLASS IDENTIFICATION

The SAE bolt strength grades range from grade 2 to grade 8. The higher the grade number, the greater the bolt strength. Identification is determined by the line marks on the top of each bolt head. The actual bolt strength grade corresponds to the number of line marks plus 2. The most commonly used metric bolt strength classes are 9.8 and 12.9. The metric strength class identification number is imprinted on the head of the bolt. The higher the class number, the greater the bolt strength. Some metric nuts are imprinted with a single-digit strength class on the nut face. Refer to the Fastener Identification and Fastener Strength Charts.

INCH		METRIC	
5/16-18		M8 X 1.25	
THREAD MAJOR DIAMETER IN INCHES	NUMBER OF THREADS PER INCH	THREAD MAJOR DIAMETER IN MILLIMETERS	DISTANCE BETWEEN THREADS IN MILLIMETERS

PR606B

Fig. 5 Thread Notation Chart – SAE and Metric

GENERAL INFORMATION (Continued)

FASTENER IDENTIFICATION

Bolt Markings and Torque - Metric

Commercial Steel Class

8.8

10.9

12.9

Bolt Head Markings

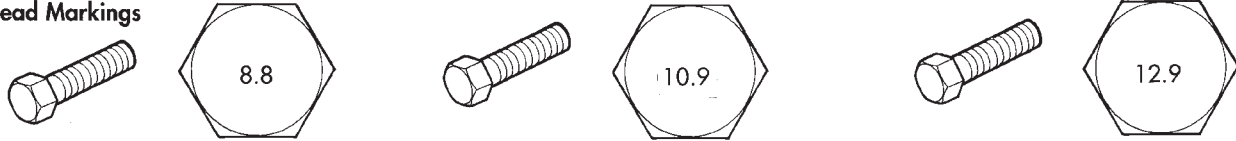

Body Size	Torque				Torque				Torque			
	Cast Iron		Aluminum		Cast Iron		Aluminum		Cast Iron		Aluminum	
	Diam.											
mm	N•m	ft-lb	N•m	ft-lb	N•m	ft-lb	N•m	ft-lb	N•m	ft-lb	N•m	ft-lb
6	9	5	7	4	14	9	11	7	14	9	11	7
7	14	9	11	7	18	14	14	11	23	18	18	14
8	25	18	18	14	32	23	25	18	36	27	28	21
10	40	30	30	25	60	45	45	35	70	50	55	40
12	70	55	55	40	105	75	80	60	125	95	100	75
14	115	85	90	65	160	120	125	95	195	145	150	110
16	180	130	140	100	240	175	190	135	290	210	220	165
18	230	170	180	135	320	240	250	185	400	290	310	230

Bolt Markings and Torque Values - U.S. Customary

SAE Grade Number

5

8

Bolt Head Markings

These are all SAE Grade 5 (3) line



Bolt Torque - Grade 5 Bolt







Bolt Torque - Grade 8 Bolt

Body Size	Cast Iron		Aluminum		Cast Iron		Aluminum	
	N•m	ft-lb	N•m	ft-lb	N•m	ft-lb	N•m	ft-lb
1/4 - 20	9	7	8	6	15	11	12	9
- 28	12	9	9	7	18	13	14	10
5/16 - 18	20	15	16	12	30	22	24	18
- 24	23	17	19	14	33	24	25	19
3/8 - 16	40	30	25	20	55	40	40	30
- 24	40	30	35	25	60	45	45	35
7/16 - 14	60	45	45	35	90	65	65	50
- 20	65	50	55	40	95	70	75	55
1/2 - 13	95	70	75	55	130	95	100	75
- 20	100	75	80	60	150	110	120	90
9/16 - 12	135	100	110	80	190	140	150	110
- 18	150	110	115	85	210	155	170	125
5/8 - 11	180	135	150	110	255	190	205	150
- 18	210	155	160	120	290	215	230	170
3/4 - 10	325	240	255	190	460	340	365	270
- 16	365	270	285	210	515	380	410	300
7/8 - 9	490	360	380	280	745	550	600	440
- 14	530	390	420	310	825	610	660	490
1 - 8	720	530	570	420	1100	820	890	660
- 14	800	590	650	480	1200	890	960	710

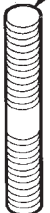
GENERAL INFORMATION (Continued)

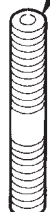
FASTENER STRENGTH

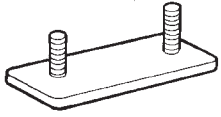
HOW TO DETERMINE BOLT STRENGTH

	Mark	Class		Mark	Class
Hexagon head bolt	 <p>Bolt head No.</p> <p>4 — 4T 5 — 5T 6 — 6T 7 — 7T 8 — 8T 9 — 9T 10 — 10T 11 — 11T</p>		Stud bolt	 <p>No mark</p>	4T
	 <p>No mark</p>	4T			
Hexagon flange bolt w/washer hexagon bolt	 <p>No mark</p>	4T	Welded bolt	 <p>Grooved</p>	6T
Hexagon head bolt	 <p>Two protruding lines</p>	5T			
Hexagon flange bolt w/washer hexagon bolt	 <p>Two protruding lines</p>	6T		4T	
Hexagon head bolt	 <p>Three protruding lines</p>	7T			
Hexagon head bolt	 <p>Four protruding lines</p>	8T			

GENERAL INFORMATION (Continued)

FASTENER USAGE

WARNING: USE OF AN INCORRECT FASTENER MAY RESULT IN COMPONENT DAMAGE OR PERSONAL INJURY.

Figure art, specifications and tightening torque references in this manual are identified in metric and SAE format.

During any maintenance or repair procedures, it is important to salvage all fasteners (nuts, bolts, etc.) for reassembly. If the fastener is not salvageable, a fastener of equivalent specification must be use.

THREADED HOLE REPAIR

Most stripped threaded holes can be repaired using a Helicoil®. Follow the manufacture recommendation for application and repair procedures.

METRIC SYSTEM

The metric system is based on quantities of one, ten, one hundred, one thousand and one million (Fig. 6).

Mega	-	(M) Million	Deci	-	(D) Tenth
Kilo	-	(K) Thousand	Centi	-	(C) Hundreth
		Milli	-	(m) Thousandth	

J901N-2

Fig. 6 Metric Prefixes

The following chart will assist in converting metric units to equivalent English and SAE units, or vise versa.

Refer to the Conversion Chart to convert torque values listed in metric Newton- meters (N·m). Also, use the chart to convert between millimeters (mm) and inches (in.)

TORQUE REFERENCES

Individual Torque Charts appear at the end of many Groups. Refer to the Standard Torque Specifications Chart for torque references not listed in the individual torque charts.

CONVERSION FORMULAS AND EQUIVALENT VALUES

Multiply	By	To Get	Multiply	By	To Get
in-lbs	x 0.11298	= Newton-Meters (N·m)	N·m	x 8.851	= in-lbs
ft-lbs	x 1.3558	= Newton-Meters (N·m)	N·m	x 0.7376	= ft-lbs
Inches Hg (60°F)	x 3.377	= Kilopascals (kPa)	kPa	x 0.2961	= Inches Hg
psi	x 6.895	= Kilopascals (kPa)	kPa	x 0.145	= psi
Inches	x 25.4	= Millimeters (mm)	mm	x 0.03937	= Inches
Feet	x 0.3048	= Meters (M)	M	x 3.281	= Feet
Yards	x 0.9144	= Meters (M)	M	x 1.0936	= Yards
Miles	x 1.6093	= Kilometers (Km)	Km	x 0.6214	= Miles
mph	x 1.6093	= Kilometers/Hr. (Km/h)	Km/h	x 0.6214	= mph
Feet/Sec.	x 0.3048	= Meters/Sec. (M/S)	M/S	x 3.281	= Feet/Sec.
Kilometers/Hr.	x 0.27778	= Meters/Sec. (M/S)	M/S	x 3.600	= Kilometers/Hr.
mph	x 0.4470	= Meters/Sec. (M/S)	M/S	x 2.237	= mph

COMMON METRIC EQUIVALENTS			
1 Inch	=	25 Millimeters	
1 Foot	=	0.3 Meter	
1 Yard	=	0.9 Meter	
1 Mile	=	1.6 Kilometers	
1 Cubic Inch	=	16 Cubic Centimeters	
1 Cubic Foot	=	0.03 Cubic Meter	
1 Cubic Yard	=	0.8 Cubic Meter	

GENERAL INFORMATION (Continued)

METRIC CONVERSION

in-lbs to N•m

N•m to in-lbs

in-lb	N•m	in-lb	N•m	in-lb	N•m	in-lb	N•m	N•m	in-lb	N•m	in-lb	N•m	in-lb	N•m	in-lb	N•m	in-lb	N•m	
2	.2260	42	4.7453	82	9.2646	122	13.7839	162	18.3032	.2	1.7702	4.2	37.1747	8.2	72.5792	12.2	107.9837	16.2	143.3882
4	.4519	44	4.9713	84	9.4906	124	14.0099	164	18.5292	.4	3.5404	4.4	38.9449	8.4	74.3494	12.4	109.7539	16.4	145.1584
6	.6779	46	5.1972	86	9.7165	126	14.2359	166	18.7552	.6	5.3107	4.6	40.7152	8.6	76.1197	12.6	111.5242	16.6	146.9287
8	.9039	48	5.4232	88	9.9425	128	14.4618	168	18.9811	.8	7.0809	4.8	42.4854	8.8	77.8899	12.8	113.2944	16.8	148.6989
10	1.1298	50	5.6492	90	10.1685	130	14.6878	170	19.2071	1	8.8511	5	44.2556	9	79.6601	13	115.0646	17	150.4691
12	1.3558	52	5.8751	92	10.3944	132	14.9138	172	19.4331	1.2	10.6213	5.2	46.0258	9.2	81.4303	13.2	116.8348	17.2	152.2393
14	1.5818	54	6.1011	94	10.6204	134	15.1397	174	19.6590	1.4	12.3916	5.4	47.7961	9.4	83.2006	13.4	118.6051	17.4	154.0096
16	1.8077	56	6.3270	96	10.8464	136	15.3657	176	19.8850	1.6	14.1618	5.6	49.5663	9.6	84.9708	13.6	120.3753	17.6	155.7798
18	2.0337	58	6.5530	98	11.0723	138	15.5917	178	20.1110	1.8	15.9320	5.8	51.3365	9.8	86.7410	13.8	122.1455	17.8	157.5500
20	2.2597	60	6.7790	100	11.2983	140	15.8176	180	20.3369	2	17.7022	6	53.1067	10	88.5112	14	123.9157	18	159.3202
22	2.4856	62	7.0049	102	11.5243	142	16.0436	182	20.5629	2.2	19.4725	6.2	54.8770	10.2	90.2815	14.2	125.6860	18.2	161.0904
24	2.7116	64	7.2309	104	11.7502	144	16.2696	184	20.7889	2.4	21.2427	6.4	56.6472	10.4	92.0517	14.4	127.4562	18.4	162.8606
26	2.9376	66	7.4569	106	11.9762	146	16.4955	186	21.0148	2.6	23.0129	6.6	58.4174	10.6	93.8219	14.6	129.2264	18.6	164.6308
28	3.1635	68	7.6828	108	12.2022	148	16.7215	188	21.2408	2.8	24.7831	6.8	60.1876	10.8	95.5921	14.8	130.9966	18.8	166.4010
30	3.3895	70	7.9088	110	12.4281	150	16.9475	190	21.4668	3	26.5534	7	61.9579	11	97.3624	15	132.7669	20.5	181.4480
32	3.6155	72	8.1348	112	12.6541	152	17.1734	192	21.6927	3.2	28.3236	7.2	63.7281	11.2	99.1326	15.2	134.5371	21	183.2182
34	3.8414	74	8.3607	114	12.8801	154	17.3994	194	21.9187	3.4	30.0938	7.4	65.4983	11.4	100.9028	15.4	136.3073	22	184.9884
36	4.0674	76	8.5867	116	13.1060	156	17.6253	196	22.1447	3.6	31.8640	7.6	67.2685	11.6	102.6730	15.6	138.0775	23	186.7586
38	4.2934	78	8.8127	118	13.3320	158	17.8513	198	22.3706	3.8	33.6342	7.8	69.0388	11.8	104.4433	15.8	139.8478	24	188.5288
40	4.5193	80	9.0386	120	13.5580	160	18.0773	200	22.5966	4	35.4045	8	70.8090	12	106.2135	16	141.6180	25	190.2990

ft-lbs to N•m

N•m to ft-lbs

ft-lb	N•m	ft-lb	N•m	ft-lb	N•m	ft-lb	N•m	N•m	ft-lb	N•m	ft-lb	N•m	ft-lb	N•m	ft-lb	N•m	ft-lb	N•m	
1	1.3558	21	28.4722	41	55.5885	61	82.7049	81	109.8212	1	.7376	21	15.9888	41	30.2400	61	44.9913	81	59.7425
2	2.7116	22	29.8280	42	56.9444	62	84.0607	82	111.1770	2	1.4751	22	16.2264	42	30.9776	62	45.7289	82	60.4801
3	4.0675	23	31.1838	43	58.3002	63	85.4165	83	112.5328	3	2.2127	23	16.9639	43	31.7152	63	46.4664	83	61.2177
4	5.4233	24	32.5396	44	59.6560	64	86.7723	84	113.8886	4	2.9502	24	17.7015	44	32.4527	64	47.2040	84	61.9552
5	6.7791	25	33.8954	45	61.0118	65	88.1281	85	115.2446	5	3.6878	25	18.4391	45	33.1903	65	47.9415	85	62.6928
6	8.1349	26	35.2513	46	62.3676	66	89.4840	86	116.6004	6	4.4254	26	19.1766	46	33.9279	66	48.6791	86	63.4303
7	9.4907	27	36.6071	47	63.7234	67	90.8398	87	117.9562	7	5.1629	27	19.9142	47	34.6654	67	49.4167	87	64.1679
8	10.8465	28	37.9629	48	65.0793	68	92.1956	88	119.3120	8	5.9005	28	20.6517	48	35.4030	68	50.1542	88	64.9054
9	12.2024	29	39.3187	49	66.4351	69	93.5514	89	120.6678	9	6.6381	29	21.3893	49	36.1405	69	50.8918	89	65.6430
10	13.5582	30	40.6745	50	67.7909	70	94.9073	90	122.0236	10	7.3756	30	22.1269	50	36.8781	70	51.6293	90	66.3806
11	14.9140	31	42.0304	51	69.1467	71	96.2631	91	123.3794	11	8.1132	31	22.8644	51	37.6157	71	52.3669	91	67.1181
12	16.2698	32	43.3862	52	70.5025	72	97.6189	92	124.7352	12	8.8507	32	23.6020	52	38.3532	72	53.1045	92	67.8557
13	17.6256	33	44.7420	53	71.8583	73	98.9747	93	126.0910	13	9.5883	33	24.3395	53	39.0908	73	53.8420	93	68.5933
14	18.9815	34	46.0978	54	73.2142	74	100.3316	94	127.4468	14	10.3259	34	25.0771	54	39.8284	74	54.5720	94	69.3308
15	20.3373	35	47.4536	55	74.5700	75	101.6862	95	128.8026	15	11.0634	35	25.8147	55	40.5659	75	55.3172	95	70.0684
16	21.6931	36	48.8094	56	75.9258	76	103.0422	96	130.1586	16	11.8010	36	26.5522	56	41.3035	76	56.0547	96	70.8060
17	23.0489	37	50.1653	57	77.2816	77	104.3980	97	131.5144	17	12.5386	37	27.2898	57	42.0410	77	56.7923	97	71.5435
18	24.4047	38	51.5211	58	78.6374	78	105.7538	98	132.8702	18	13.2761	38	28.0274	58	42.7786	78	57.5298	98	72.2811
19	25.7605	39	52.8769	59	79.9933	79	107.1196	99	134.2260	19	14.0137	39	28.7649	59	43.5162	79	58.2674	99	73.0187
20	27.1164	40	54.2327	60	81.3491	80	108.4654	100	135.5820	20	14.7512	40	29.5025	60	44.2537	80	59.0050	100	73.7562

in. to mm

mm to in.

in.	mm	in.	mm	in.	mm	in.	mm	mm	in.	mm	in.	mm	mm	in.	mm	in.	mm	in.	
.01	.254	.21	5.334	.41	10.414	.61	15.494	.81	20.574	.01	.00039	.21	.00827	.41	.01614	.61	.02402	.81	.03189
.02	.508	.22	5.588	.42	10.668	.62	15.748	.82	20.828	.02	.00079	.22	.00866	.42	.01654	.62	.02441	.82	.03228
.03	.762	.23	5.842	.43	10.922	.63	16.002	.83	21.082	.03	.00118	.23	.00906	.43	.01693	.63	.02480	.83	.03268
.04	1.016	.24	6.096	.44	11.176	.64	16.256	.84	21.336	.04	.00157	.24	.00945	.44	.01732	.64	.02520	.84	.03307
.05	1.270	.25	6.350	.45	11.430	.65	16.510	.85	21.590	.05	.00197	.25	.00984	.45	.01772	.65	.02559	.85	.03346
.06	1.524	.26	6.604	.46	11.684	.66	16.764	.86	21.844	.06	.00236	.26	.01024	.46	.01811	.66	.02598	.86	.03386
.07	1.778	.27	6.858	.47	11.938	.67	17.018	.87	22.098	.07	.00276	.27	.01063	.47	.01850	.67	.02638	.87	.03425
.08	2.032	.28	7.112	.48	12.192	.68	17.272	.88	22.352	.08	.00315	.28	.01102	.48	.01890	.68	.02677	.88	.03465
.09	2.286	.29	7.366	.49	12.446	.69	17.526	.89	22.606	.09	.00354	.29	.01142	.49	.01929	.69	.02717	.89	.03504
.10	2.540	.30	7.620	.50	12.700	.70	17.780	.90	22.860	.10	.00394	.30	.01181	.50	.01969	.70	.02756	.90	.03543
.11	2.794	.31	7.874	.51	12.954	.71	18.034	.91	23.114	.11	.00433	.31	.01220	.51	.02008	.71	.02795	.91	.03583
.12	3.048	.32	8.128	.52	13.208	.72	18.288	.92	23.368	.12	.00472	.32	.01260	.52	.02047	.72	.02835	.92	.03622
.13	3.302	.33	8.382	.53	13.462	.73	18.542	.93	23.622	.13	.00512	.33	.01299	.53	.02087	.73	.02874	.93	.03661
.14	3.556	.34	8.636	.54	13.716	.74	18.796	.94	23.876	.14	.00551	.34	.01339	.54	.02126	.74	.02913	.94	.03701
.15	3.810	.35	8.890	.55	13.970	.75	19.050	.95	24.130	.15	.00591	.35	.01378	.55	.02165	.75	.02953	.95	.03740
.16	4.064	.36	9.144	.56	14.224	.76	19.304	.96	24.384	.16	.00630	.36	.01417	.56	.02205	.76	.02992	.96	.03780
.17	4.318	.37	9.398	.57	14.478	.77	19.558	.97	24.638	.17	.00669	.37	.01457	.57	.02244	.77	.03032	.97	.03819
.18	4.572	.38	9.652	.58	14.732	.78	19.812	.98	24.892	.18	.00709	.38	.01496	.58	.02283	.78	.03071	.98	.03858
.19	4.826	.39	9.906	.59	14.986	.79	20.066	.99	25.146	.19	.00748	.39	.01535	.59	.02323	.79	.03110	.99	.03898
.20	5.080	.40	10.160	.60	15.240	.80	20.320	1.00											

GENERAL INFORMATION (Continued)

TORQUE SPECIFICATIONS

SPECIFIED TORQUE FOR STANDARD BOLTS

Class	Diameter mm	Pitch mm	Specified torque					
			Hexagon head bolt			Hexagon flange bolt		
			N•m	kgf-cm	ft-lbf	N•m	kgf-cm	ft-lbf
4T	6	1	5	55	48 in.-lbf	6	60	52 in.-lbf
	8	1.25	12.5	130	9	14	145	10
	10	1.25	26	260	19	29	290	21
	12	1.25	47	480	35	53	540	39
	14	1.5	74	760	55	84	850	61
	16	1.5	115	1,150	83	—	—	—
5T	6	1	6.5	65	56 in.-lbf	7.5	75	65 in.-lbf
	8	1.25	15.5	160	12	17.5	175	13
	10	1.25	32	330	24	36	360	26
	12	1.25	59	600	43	65	670	48
	14	1.5	91	930	67	100	1,050	76
	16	1.5	140	1,400	101	—	—	—
6T	6	1	8	80	69 in.-lbf	9	90	78 in.-lbf
	8	1.25	19	195	14	21	210	15
	10	1.25	39	400	29	44	440	32
	12	1.25	71	730	53	80	810	59
	14	1.5	110	1,100	80	125	1,250	90
	16	1.5	170	1,750	127	—	—	—
7T	6	1	10.5	110	8	12	120	9
	8	1.25	25	260	19	28	290	21
	10	1.25	52	530	38	58	590	43
	12	1.25	95	970	70	105	1,050	76
	14	1.5	145	1,500	108	165	1,700	123
	16	1.5	230	2,300	166	—	—	—
8T	8	1.25	29	300	22	33	330	24
	10	1.25	61	620	45	68	690	50
	12	1.25	110	1,100	80	120	1,250	90
9T	8	1.25	34	340	25	37	380	27
	10	1.25	70	710	51	78	790	57
	12	1.25	125	1,300	94	140	1,450	105
10T	8	1.25	38	390	28	42	430	31
	10	1.25	78	800	58	88	890	64
	12	1.25	140	1,450	105	155	1,600	116
11T	8	1.25	42	430	31	47	480	35
	10	1.25	87	890	64	97	990	72
	12	1.25	155	1,600	116	175	1,800	130

